

Train Antenna

430 – 470 MHz / 870 – 960 MHz and GPS 1575 MHz 870 10006

KATHREIN

Antennen · Electronic

- Multi-band antenna: 430 – 470 MHz / 870 – 960 MHz and GPS.
- The antenna can be operated in all frequency ranges simultaneously.
- Low profile antenna in fiberglass radome.
- The antenna fulfils the requirements according to EN 50155.

Type No.	870 10006
Antenna multi-band	
Input	N female
Frequency range	430 – 470 MHz 870 – 960 MHz
VSWR	< 1.5
Gain	0 dB (ref. to the quarter-wave antenna)
Impedance	50 Ω
Polarization	Vertical
Max. power	100 W (at 50° C ambient temperature)
Inner conductor	D.C. grounded
Antenna GPS	
Input	Cable RG 316/U of 225 mm length with TNC male connector
Frequency range	1575.42 ±1 MHz
VSWR	< 1.5
Polarization	Right hand circular
Gain (90° elevation)	2 dB (ref. to the circularly polarized isotropic antenna)
Impedance	50 Ω
Inner conductor	D.C. grounded
Weight	Approx. 0.5 kg
Packing size, L x W x H	150 x 90 x 190 mm
Height	150 mm

Material: Radiator: Copper and brass.
Flange: Aluminum. Radome: Fiberglass.
All screws and nuts: Stainless steel.
Colour: Grey.

Mounting: On a conductive surface with a minimum size of 1000 x 1000 mm using 4 M10 bolts.

Grounding and high voltage protection: This antenna, tested by an independent institute and approved by the "Deutsche Bahn AG", is D.C. grounded to protect against lightning and high-tension lines.

Accessories: Low noise amplifier GPS type no. 860 10142 (please order separately).

Warning: If the antenna is operated without the pre-amplifier type no. 860 10142, please note the following points.

- Due to the fact that the inner conductor of the antenna GPS is DC grounded, the input of the GPS receiver is loaded with a DC short circuit. If the GPS receiver provides a remote DC power supply, this could damage the GPS receiver.
- At the input of the antenna GPS a level of –25 dB below the signal applied at the input of the antenna two-band appears. Depending on the level of the signal applied at the input of the antenna two-band, the GPS receiver may be overloaded or damaged.

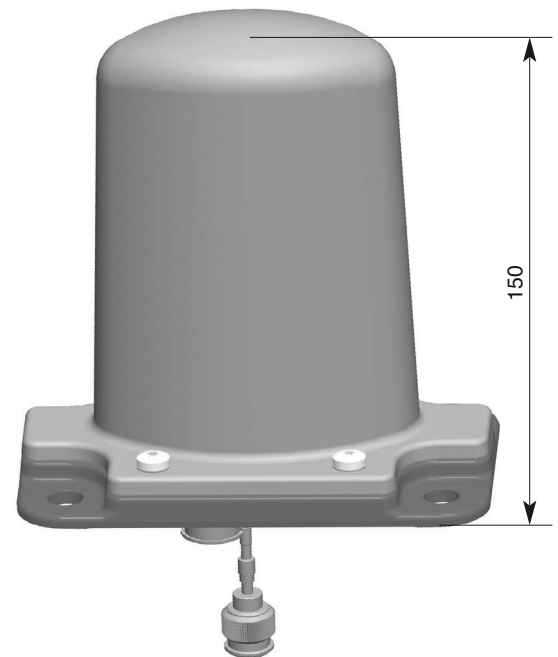

Mounting flange:

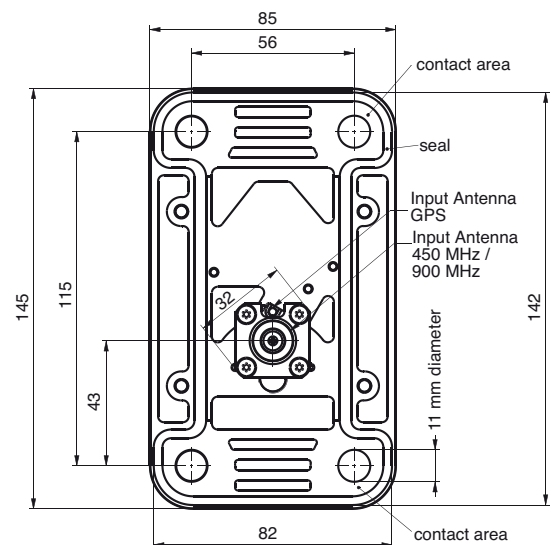

Mounting hole for the connector: 33 mm (max. 35 mm)

Note: Mounting surface must be free from paint for electrical contact.

Evenness of opposite surface 0.2 mm.

Use a cap nut or hex-head screw plus the enclosed sealing washer.

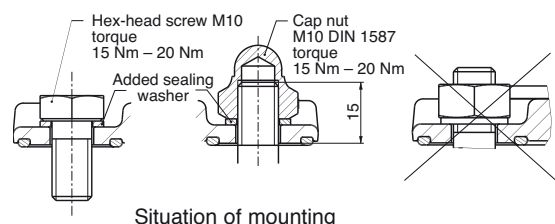

Situation of mounting

936.2962/c Subject to alteration.